

Flat Pattern view
SCALE: 1:2

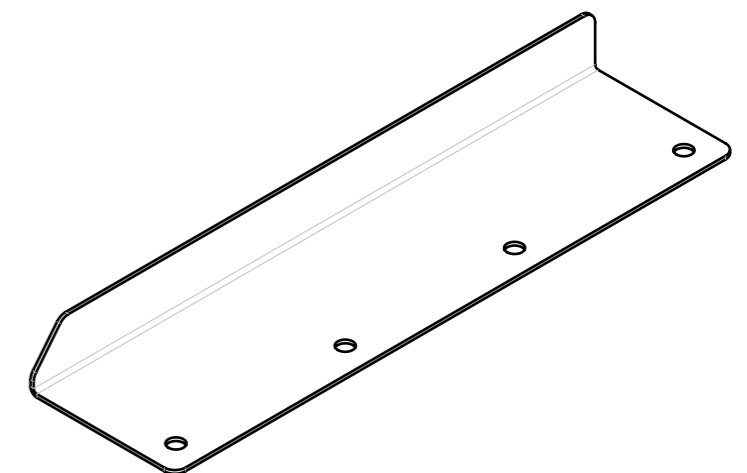
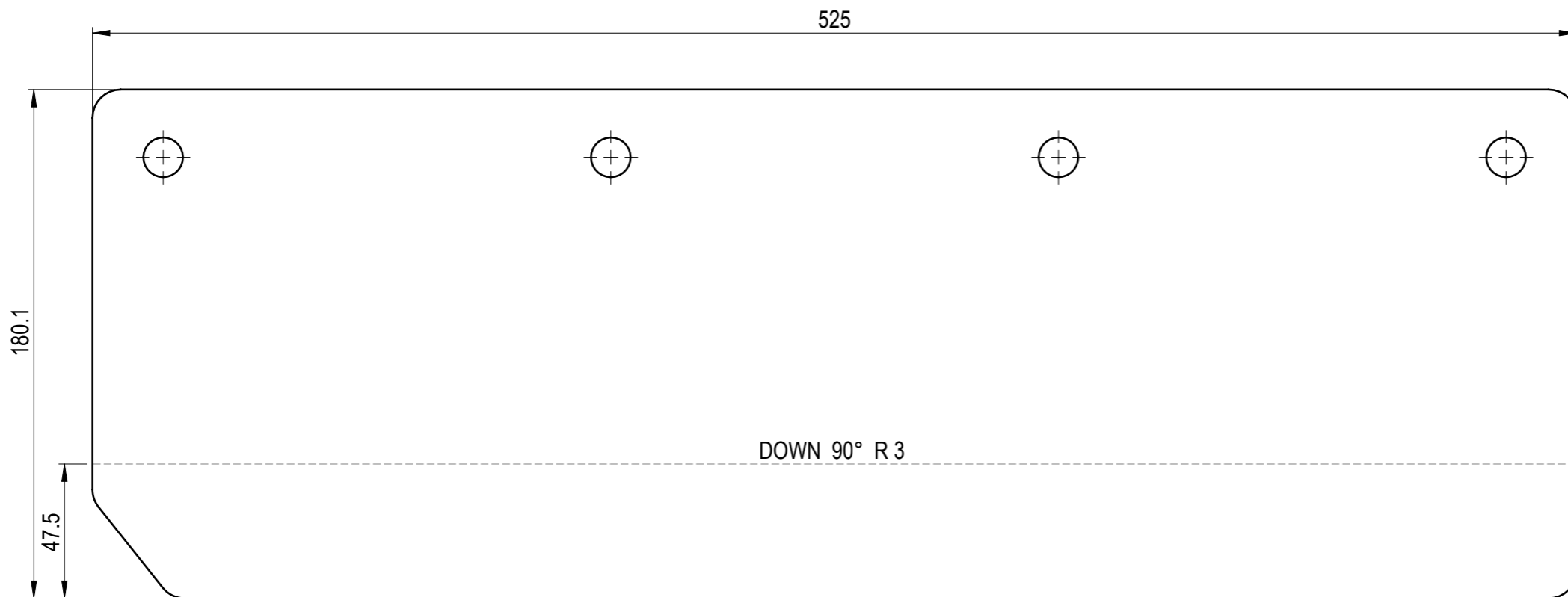

SHEET METAL INFORMATION	
Length, mm	525
Width, mm	180.1
Thickness, mm	3
Inside Bend Radius, mm	3
K-Factor	0.5
No. of Bends	1

WEMPS ENGINEERING SERVICES	MATERIAL	DX51D+Z275	WEIGHT	2.185 Kg	DEBURR AND BREAK SHARP EDGES	REVISION	DATE
	SURFACE PROTECTION	Painting G3.04 ISO 12944	MACHINING	ISO 2768 mK	DO NOT SCALE DRAWING		5/29/2025
	NAME	SIGNATURE	PART NO.	105-09200-05			
Designed by	D. Dislers		DESCRIPTION	Exit side corner plate			
Drawn by	D. Dislers						SHEET 1/1
Technical ref.							